

M23 STAINLESS STEEL SERIES L/A & S

M23 Power and Signal Connectors



HYPERBOLOID TECHNOLOGY

Smiths Connectors offers an extensive range of superior contact technologies suitable for standard and custom solutions. Hypertac® (HYPERboloid conTACT) is the original superior performing hyperboloid contact technology designed for use in all applications and in harsh and demanding environments where high reliability and safety are critical. The inherent electrical and mechanical characteristics of the Hypertac hyperboloid contact ensures unrivalled performance in terms of reliability, number of mating cycles, low contact force and minimal contact resistance. The shape of the contact sleeve is formed by hyperbolically arranged contact wires, which align themselves elastically as contact lines around the pin, providing a number of linear contact paths.

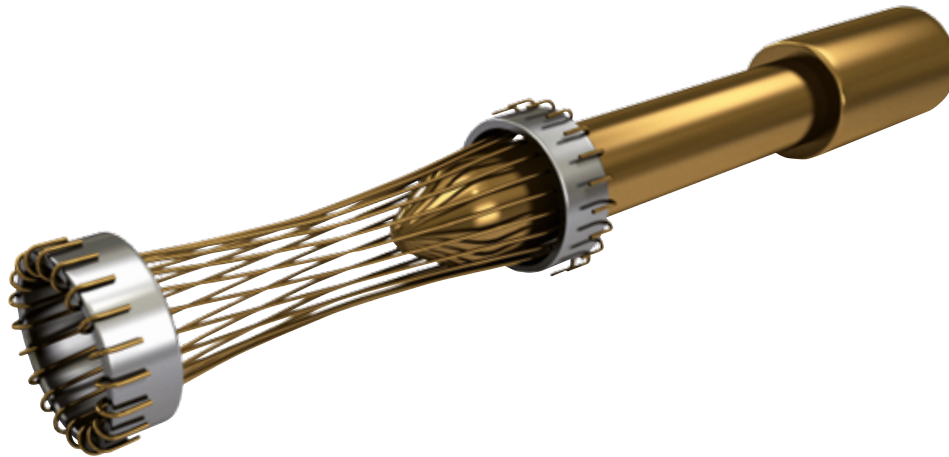

FEATURE

LOW INSERTION/EXTRACTION FORCES

The angle of the socket wires allows tight control of the pin insertion and extraction forces. The spring wires are smoothly deflected to make line contact with the pin.

LONG CONTACT LIFE

The smooth and light wiping action minimizes wear on the contact surfaces. Contacts perform up to 100,000 insertion/extraction cycles with no degradation in performance.

LOWER CONTACT RESISTANCE

The design provides a far greater contact area and the wiping action of the wires insures a clean and polished contact surface. Our contact technology has about half the resistance of conventional contact designs.

HIGHER CURRENT RATINGS

The design parameters of the contact (e.g., the number, diameter and angle of the wires) may be modified for any requirement. The number of wires can be increased so the contact area is distributed over a larger surface. Thus, the high current carried by each wire because of its intimate line contact, can be multiplied many times.

IMMUNITY TO SHOCK & VIBRATION

The low mass and resultant low inertia of the wires enable them to follow the most abrupt or extreme excursions of the pin without loss of contact. The contact area extends 360° around the pin and is uniform over its entire length. The 3 dimensional symmetry of the Hypertac contact design guarantees electrical continuity in all circumstances.

BENEFIT

HIGH DENSITY INTERCONNECT SYSTEMS

Significant reductions in size and weight of sub-system designs. No additional hardware is required to overcome mating and un-mating forces.

LOW COST OF OWNERSHIP

The Hypertac contact technology will surpass most product requirements, thus eliminating the burden and cost of having to replace the connector or the entire subsystem.

LOW POWER CONSUMPTION

The lower contact resistance of our technology results in a lower voltage drop across the connector reducing the power consumption and heat generation within the system.

MAXIMUM CONTACT PERFORMANCE

The lower contact resistance of the Hypertac contact reduces heat build-up; therefore Hypertac contacts are able to handle far greater current in smaller contact assemblies without the detrimental effects of high temperature.

RELIABILITY UNDER HARSH ENVIRONMENTS

Harsh environmental conditions require connectors that will sustain their electrical integrity even under the most demanding conditions such as shock and vibration. The Hypertac contact provides unmatched stability in demanding environments when failure is not an option.

TABLE OF CONTENTS

M23 STAINLESS STEEL

- ▶ Features and Benefits.....2

M23 POWER CONNECTORS SERIES L/A

- ▶ Type Overview3
- ▶ Technical Characteristics.....4
- ▶ How to Order.....5
- ▶ Connector Types:
 - Receptacles..... 6 - 7
 - Extensions8
 - Plugs9
 - Panel Feed Through 10 - 11
- ▶ Contacts
 - Machined Pins12
 - Machined Sockets13
- ▶ Assembly Instructions
 - Receptacles..... 14 - 15
 - Extension16
 - Plug17
 - Panel Feed Through 18 - 19

M23 SIGNAL CONNECTORS SERIES S

- ▶ Type Overview21
- ▶ Technical Characteristics.....22
- ▶ How to Order.....23
- ▶ Connector Types:
 - Receptacles..... 24 - 27
 - Extensions28 - 29
 - Plugs30 - 31
- ▶ Contacts
 - Machined Pins32
 - Machined Sockets33
 - Stamped Pins.....34
 - Stamped Sockets35
- ▶ Assembly Instructions
 - Extension36
 - Plug37
 - Receptacles..... 38 - 39
- ▶ Tools.....40 - 41
- ▶ Cable Clamps and Accessoires.....42 - 43

FEATURES & BENEFITS

- ▶ *Optimised Design*
- ▶ *Corrosion Resistant*
- ▶ *Reliable Contact Technology*
- ▶ *Environmentally Sealed to IP67*

CORROSION RESISTANT

The Smiths Connectors M23 Stainless Steel series have been specifically developed for applications operating in highly corrosive environments. Manufactured from high grade stainless steel and advanced polymers, these connectors are ideally suited for use in the Medical, Pharmaceutical, Maritime, Automotive and Food and Beverage Industries. Environmentally sealed to IP67 and chemically resistant to both Lye and Acids, these connectors are protected against the harshest of Industrial processing environments.

OPTIMISED DESIGN

In addition to specialist materials, these connectors feature a smooth outer body design to aid industrial wash down processes, by preventing the entrapment of dirt and contaminants. A complete range of options and accessories are available as standard, making this series suitable for a wide range of applications.

HYPERTAC HYPERBOLOID CONTACT

Hyperboloid contact technology is ideally suited for use in harsh and demanding environments where high reliability and safety are critical. The electrical and mechanical characteristics of the contact ensure unrivalled performance in terms of reliability, number of mating cycles, low contact forces and electrical stability over time. These performance characteristics provide a real commercial benefit in terms of the total installed cost of ownership.



FEATURES

- ▶ **Long life and low rate of wear through excellent shock and vibration resistance**
- ▶ **Electrical continuity ensuring free performance**
- ▶ **Easy assembly**
- ▶ **Corrosion resistant**
- ▶ **Environmentally sealed**
- ▶ **Vibration resistant**
- ▶ **RoHS compliant**
- ▶ **UL/CSA approval file No. 178462**

TYPE OVERVIEW

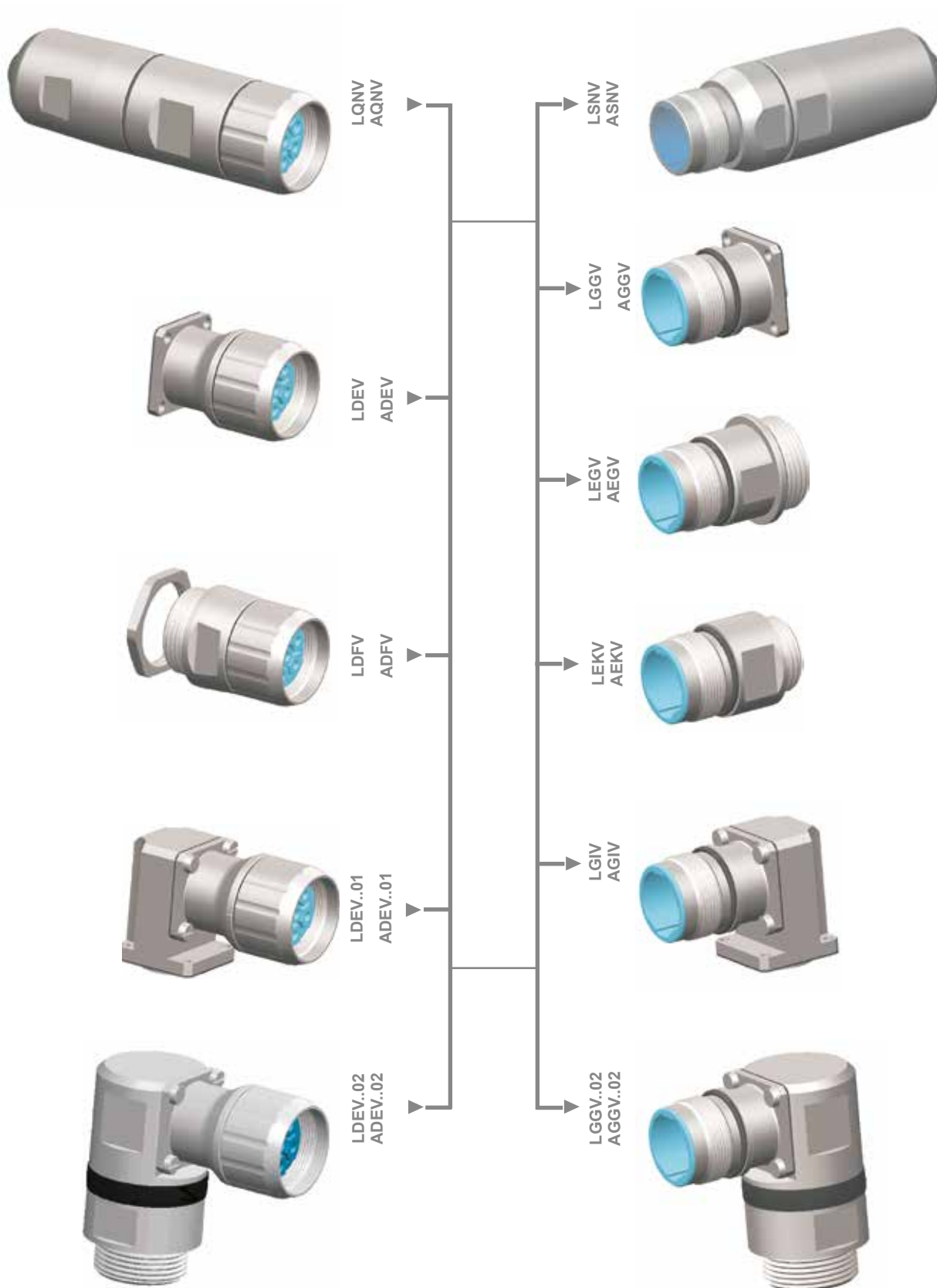

TECHNICAL CHARACTERISTICS

STAINLESS STEEL		STANDARDS
Contact diameter 6poles	6 x Ø 2mm	-
Contact diameter 8poles	4 x Ø 1mm + 4 x Ø 2mm	-
MATERIAL		
Shell	V2A (V4A on demand)	-
Contacts	CuZn alloy	-
Insert	PA, PBT	-
Sealing	FKM, EPDM	-
FINISHES		
Shell plating	passivated	-
Contacts plating	Gold over nickel	-
ELECTRICAL		
Current rating	9 A (contact Ø 1mm) 8 A (contact Ø 1mm) 7 A (contact Ø 1mm) 22 A (contact Ø 2mm) 20 A (contact Ø 2mm) 14 A (contact Ø 2mm)	EN 61984 USR / UL1977 CNR / UL1977 EN 61984 USR / UL1977 CNR / UL1977
Voltage rating	250 V (contact Ø 1mm) 250 V (contact Ø 1mm) 630 V (contact Ø 2mm) 600 V (contact Ø 2mm)	EN 61984 USR / CNR / UL1977 EN 61984 USR / CNR / UL1977
Withstanding voltage	2500 V (contact Ø 1mm) 6000 V (contact Ø 2mm)	EN 61984 EN 61984
Contact resistance	<5 mΩ (contact Ø 1mm) <3 mΩ (contact Ø 2mm)	EN 61984 EN 61984
Insulation resistance	10 ¹³ Ωcm	EN 61984
Overvoltage category	III	EN 61984
PHYSICAL AND ENVIRONMENTAL		
Operating temperature range	-40°C ... 125°C -40°C ... 110°C	EN 61984 UL1977
Storage conditions	-40°C ... 70°C/ min. humidity 40%	-
Environmental level	IP67 (mated)	DIN EN 60529
Contamination level	3 (mated)	EN 61984
Installation altitude	up to 2000 m	EN 61984
Fire & Smoke	Recognition file No E 178462	UL 1977

Consult factory for details



HOW TO ORDER

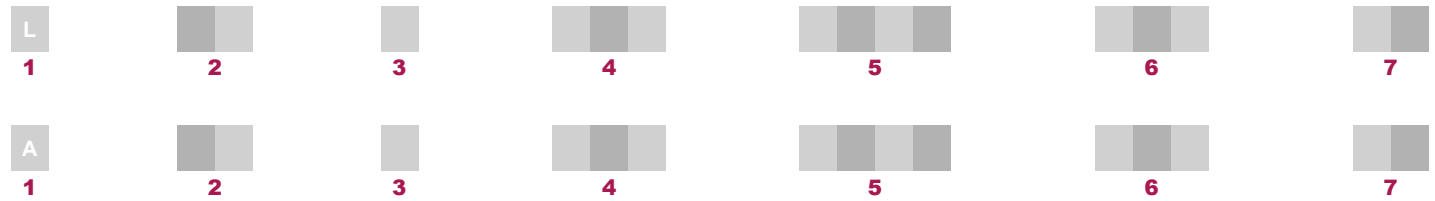

1 CONNECTOR FAMILIES

L M23 stainless steel circular connectors, Series L

A M23 stainless steel circular connectors UL/CSA, Series A

2 CONNECTOR DESIGN

Q N plug with variable shield connection and variable cable clamp
S N extension with variable shield connection and variable cable clamp
D E panel feed through with square flange
D F panel feed through, threaded connection M 25x1.5

G G straight receptacle with flange
E G straight receptacle, threaded connection M 25x1.5
E K straight receptacle, threaded connection M 20x1.5
E E straight receptacle, axial sealing, long version
G I angled receptacle with flange

3 PLATING

V passivated

4 INSERTS

0 6 A 6 way for pins 6 x Ø 2mm
0 6 B 6way for sockets 6 x Ø 2mm

0 8 A 8way for pins 4 x Ø 1mm + 4 x Ø 2mm
0 8 B 8way for sockets 4 x Ø 1mm + 4 x Ø 2mm

5 TERMINATION STYLE

N N N N without contacts, loose contacts to be ordered separately
F R B N including machined sockets, 6 x Ø 2mm AWG 20-16
F R D N including machined sockets, 6 x Ø 2mm AWG 18-14
F R K B including machined sockets, 4 x Ø 1mm AWG 24-18 + 4 x Ø 2mm, AWG 20-16
F R K D including machined sockets, 4 x Ø 1mm AWG 24-18 + 4 x Ø 2mm, AWG 18-14

M R C N including machined pins, 6 x Ø 2mm AWG 20-16
M R K N including machined pins, 6 x Ø 2mm AWG 18-14
M R P N including machined pins, 6 x Ø 2mm AWG 16-14
M R E C including machined pins, 4 x Ø 1mm AWG 24-18 + 4 x Ø 2mm, AWG 20-16
M R E K including machined pins, 4 x Ø 1mm AWG 24-18 + 4 x Ø 2mm, AWG 18-14
M R E P including machined pins, 4 x Ø 1mm AWG 24-18 + 4 x Ø 2mm, AWG 16-14

6 CABLE CLAMPING

0 0 0 without cable clamp for receptacles and panel feed through
1 7 0 variable clamp for cable Ø 7.7mm to 14.5mm can be used for all shielded and non shielded cables
3 0 5 for cable diameter 5 - 9 mm, can be used for shielded and non-shielded cables
3 0 6 for cable diameter 9 - 15 mm, can be used for shielded and non-shielded cables
3 0 7 for cable diameter 16 mm, can be used for shielded and non-shielded cables

7 VERSION NUMBER

0 1 depending on type and special design see detailed description of connector design LDEV / ADEV
0 2 depending on type and special design see detailed description of connector design LGGV / AGGV / LDEV / ADEV

► RECEPTACLES

POWER RECEPTACLES SERIES L (UL VERSION SERIES A) WITH CRIMP CONTACTS

Contact arrangements view mating side

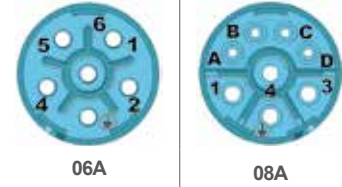

termination cross section of the pins in mm²

Layout
Description
Part number code

Straight receptacle, radial sealing to the device, mounting flange



Part number incl. O-ring against vibration on demand

Straight receptacle, axial sealing to the device, connecting thread M25 x 1.5

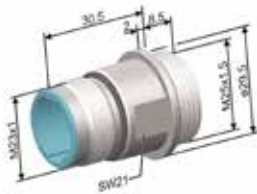

Part number incl. O-ring against vibration on demand

Straight receptacle, axial sealing to the device, connecting thread M20 x 1.5



Part number incl. O-ring against vibration on demand

shell	insert	termination cross section of the pins in mm ²				cable clamp
		6 x 0.5 - 1.5	6 x 0.75 - 2.5	4 x 0.24 - 1 4 x 0.5 - 1.5	4 x 0.24 - 1 4 x 0.75 - 2.5	
LGGV AGGV*	06A	MRCN				000
			MRKN			
08A				MREC		000
					MREK	
LEGV AEGV*	06A	MRCN				000
			MRKN			
08A				MREC		000
					MREK	
LEKV AEKV*	06A	MRCN				000
			MRKN			
08A				MREC		000
					MREK	

* UL-Version

RECEPTACLES

POWER RECEPTACLES SERIES L (UL VERSION SERIES A) WITH CRIMP CONTACTS

Contact arrangements view mating side



06A



08A

termination cross section of the pins in mm²

Layout
Description
Part number code

shell	insert	termination cross section of the pins in mm ²				cable clamp
		6 x 0.5 - 1.5	6 x 0.75 - 2.5	4 x 0.24 - 1 4 x 0.5 - 1.5	4 x 0.24 - 1 4 x 0.75 - 2.5	
LGIV AGIV*	06A	MRCN				000
			MRKN			
08A				MREC		000 02
					MREK	

Fixed angled receptacle, radial sealing to the device, mounting flange

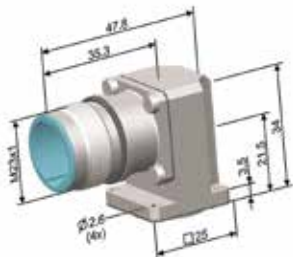

Part number incl. O-ring against vibration on demand

Rotatable receptacle, axial sealing to the device, connecting thread M25 x 1.5



Part number incl. O-ring against vibration on demand

* UL-Version

Drilling drawings

LGGV, LGIV
AGGV, AGIV

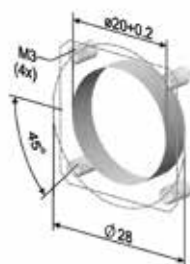

LEKV
AEKV



LEGV, LGGV..02
AEGV, AGGV..02



▶ EXTENSIONS

POWER EXTENSIONS SERIES L (UL VERSION SERIES A) WITH CRIMP CONTACTS

Contact arrangements view mating side

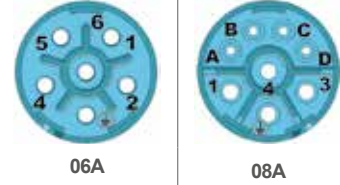

termination cross section of the pins in mm²

Layout
Description
Part number code

Extension with earth connection, variable shield connection and variable cable clamp Ø 7.7 - 14.5 mm

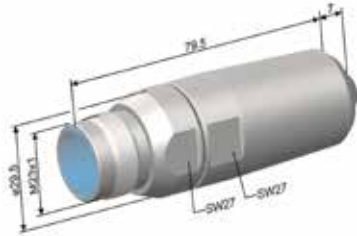

Part number incl. O-ring against vibration on demand

Gehäuse shell	insert	termination cross section of the pins in mm ²				cable clamp
		6 x 1.5 - 2.5		4 x 0.24 - 1 4 x 1.5 - 2.5		
LSNV ASNV*	06A	MRPN				170
	08A			MREP		

* UL-Version

PLUGS

POWER PLUGS SERIES L (UL VERSION SERIES A) WITH CRIMP CONTACTS

Contact arrangements view mating side



06B



08B

termination cross section of the pins in mm²

Layout
Description
Part number code

Plug with earth connection, variable shield connection and variable cable clamps



shell	insert	termination cross section of the pins in mm ²				cable clamp
		6 x 0.5 - 1.5	6 x 0.75 - 2.5	4 x 0.24 - 1 4 x 0.5 - 1.5	4 x 0.24 - 1 4 x 0.75 - 2.5	
LQNV AQNV*	06B	FRBN				305 306 307
			FRDN			
	08B			FRKB		
					FRKD	

* UL-Version

▶ PANEL FEED TROUGH

POWER PANEL FEED THROUGH SERIES L (UL VERSION SERIES A) WITH CRIMP CONTACTS

Contact arrangements view mating side

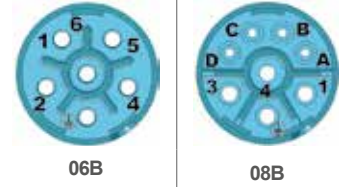

termination cross section of the pins in mm²

Layout
Description
Part number code

Straight panel feed through, radial sealing to the device, mounting flange



Straight panel feed through, axial sealing, connecting thread M25x1,5



shell	insert	termination cross section of the pins in mm ²				cable clamp
		6 x 0.5 - 1.5	6 x 0.75 - 2.5	4 x 0.24 - 1 4 x 0.5 - 1.5	4 x 0.24 - 1 4 x 0.75 - 2.5	
LDEV ADEV*	06B	FRBN				000
			FRDN			
	08B			FRKB		
					FRKD	
LDFV ADFV*	06B	FRBN				000
			FRDN			
	08B			FRKB		
					FRKD	

* UL-Version

▶ PANEL FEED TROUGH

POWER PANEL FEED THROUGH SERIES L (UL VERSION SERIES A) WITH CRIMP CONTACTS

Contact arrangements view mating side



06B

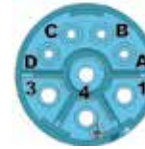

08B

termination cross section of the pins in mm²

Layout
Description
Part number code

Angled panel feed through, axial sealing to the device, mounting flange

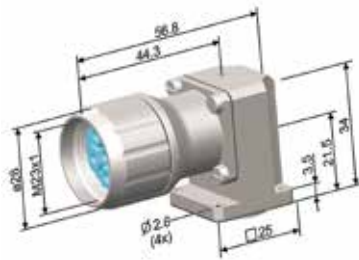

shell	insert	termination cross section of the pins in mm ²				cable clamp
		6 x 0.5 - 1.5	6 x 0.75 - 2.5	4 x 0.24 - 1 4 x 0.5 - 1.5	4 x 0.24 - 1 4 x 0.75 - 2.5	
LDEV ADEV*	06B	FRBN				000 01
			FRDN			
LDEV ADEV*	08B			FRKB		000 02
					FRKD	

Rotatable angled panel feed through, axial sealing, connecting thread M25x1,5



* UL-Version



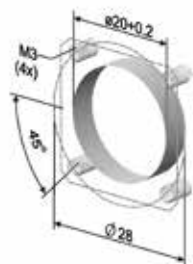

Drilling drawings

LDEV, LDEV..01
ADEV, ADEV..01

LDFV, LDEV..02
ADFV, ADEV..02







CONTACTS

MACHINED PINS SERIES L (UL VERSION SERIES A)				
Type	E	C	K	P
Contact diameter [mm]	1	2	2	2
Part number and layout	021.129.1020 	021.101.2000 	021.147.2000 	021.279.1020 
Termination cross section* [mm ²] AWG	0.24 - 1 (24 - 18)	0.5 - 1.5 (20 - 16)	0.75 - 2.5 (18 - 14)	1.5 - 2.5 (16 - 14)
Maximum conductor diameter [mm]	1.3	1.8	2.3	2.3
Maximum insulation diameter [mm]	-	-	-	3.5
For following number of contacts	8	6/8	6/8	6/8

TOOLING				
Crimping tool	B151	B151	B151	B151
Positioner	B156	B157	B157	B165
Insertion tool	B118	B117	B117	-
Extraction tool	B038/A	B037/A	B037/A	-

*Mentioned crimp ranges are recommendations and only valid with flexible wires H05(07)V-K [mm²] acc. to DIN VDE 0281/0282 pp and with non compressed standard cables and wires acc. to DIN VDE 0295. It is possible that due to another structure of wires further cross sections and currents can be processed.

CONTACTS

MACHINED SOCKETS SERIES L (UL VERSION SERIES A)				
Type	K	B	D	H
Contact diameter [mm]	1	2	2	2
Part number and layout	020.232.2000 	020.090.1020 	020.105.1020 	020.123.1020 
Termination cross section* [mm ²] AWG	0.24 - 1 (24 - 18)	0.5 - 1.5 (20 - 16)	0.75 - 2.5 (18 - 14)	0.75 - 2.5 (18 - 14)
Maximum conductor diameter [mm]	1.3	1.9	2.3	2.3
Maximum insulation diameter [mm]	2.1	-	-	4.5
For following number of contacts	8	6/8	6/8	6

TOOLING				
Crimping tool	B151** B150	B151	B151	B151 B152 B179
Positioner	B252** B055/A	B157	B157	B154
Insertion tool	B118	-	-	-
Extraction tool	B056/A	-	-	-

*Mentioned crimp ranges are recommendations and only valid with flexible wires H05(07)V-K [mm²] acc. to DIN VDE 0281/0282 pp and with non compressed standard cables and wires acc. to DIN VDE 0295. It is possible that due to another structure of wires further cross sections and currents can be processed.

**preferred crimping tool

▶ ASSEMBLY INSTRUCTIONS

POWER RECEPTACLE LGGV... LEGV... LEKV... LGIV... LGGV..02

Page 1 of 2

Stripping Length	
Machined Contacts	
A	7 mm

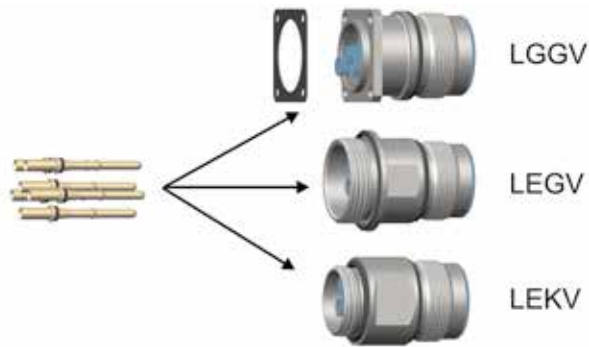

Assembly

1



2

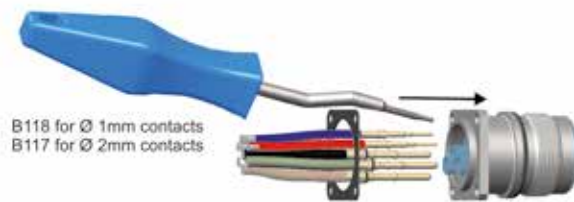

Dismantling

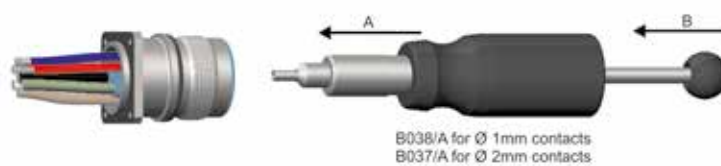

After assembly the connector has to be checked for the functions of the safety precautions (according to EN 60204-1, VDE 0113 Teil 1)

▶ ASSEMBLY INSTRUCTIONS

POWER RECEPTACLE LGGV... LEGV... LEKV... LGIV... LGGV.02

Page 2 of 2

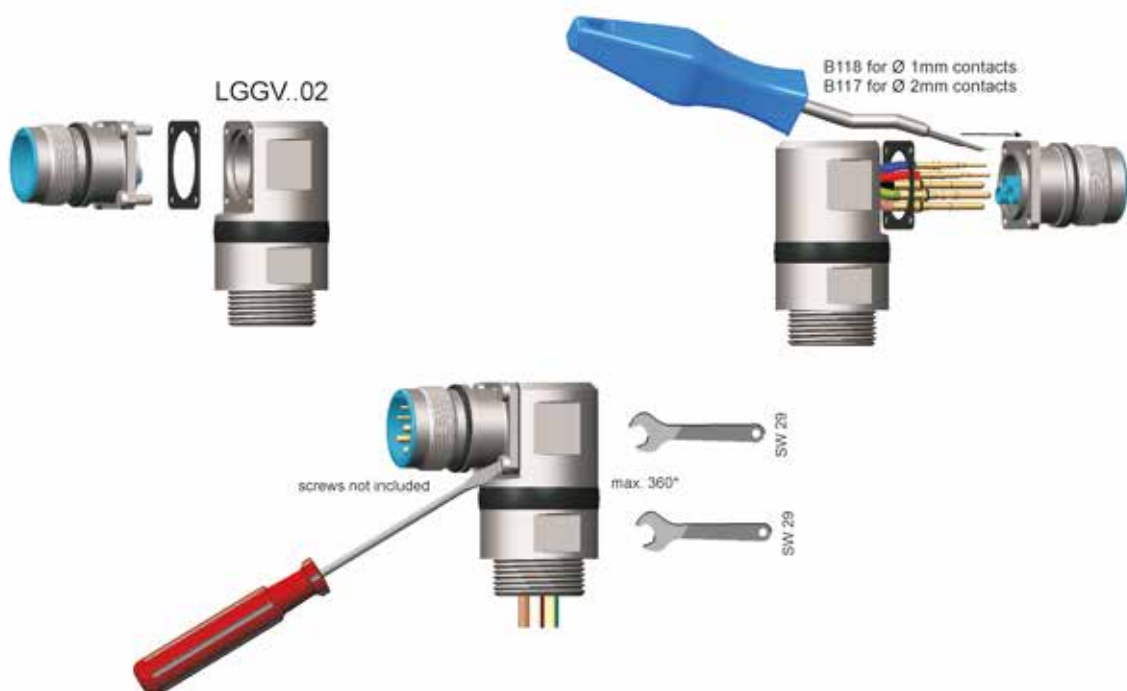
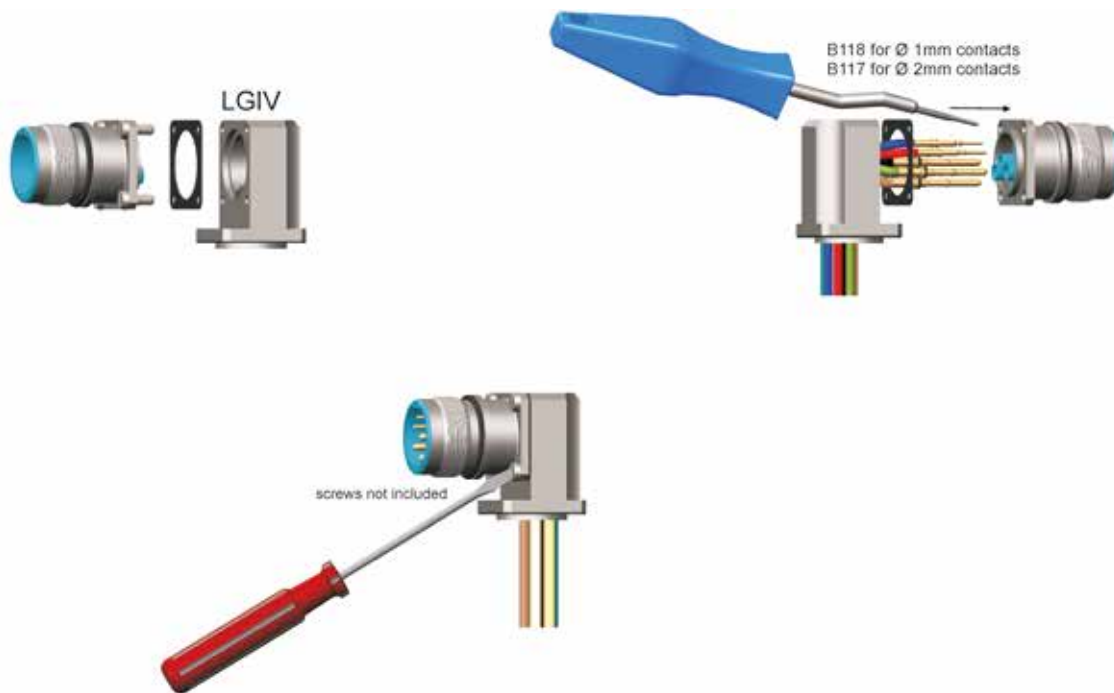

After assembly the connector has to be checked for the functions of the safety precautions (according to EN 60204-1, VDE 0113 Teil 1)

► ASSEMBLY INSTRUCTIONS

POWER EXTENSION LSNV...

Page 1 of 1

Stripping Length	
Machined Contacts	
A	7 mm



Assembly

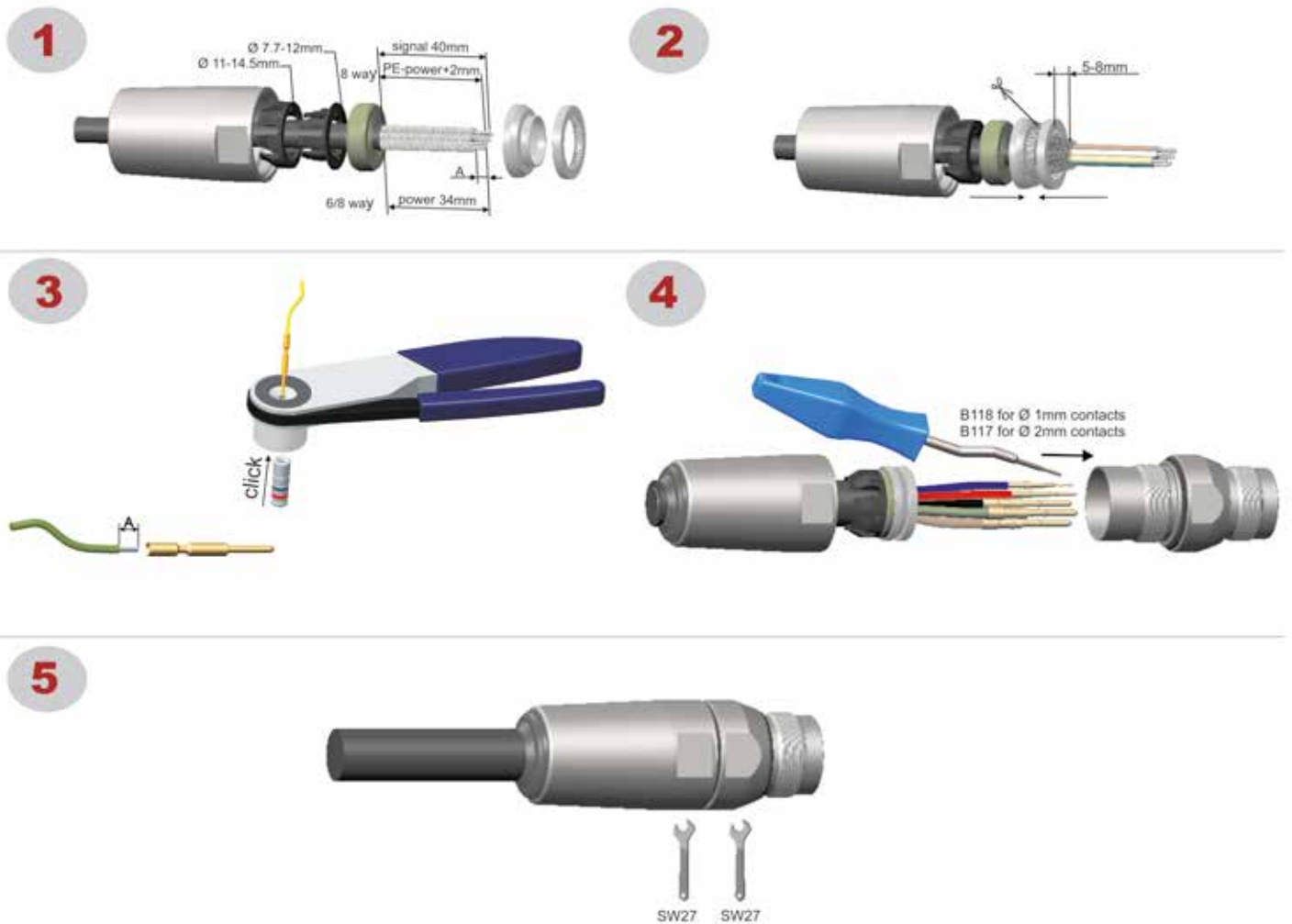

Dismantling



After assembly the connector has to be checked for the functions of the safety precautions (according to EN 60204-1, VDE 0113 Teil 1)

ASSEMBLY INSTRUCTIONS

POWER PLUG

Page 1 of 1

Stripping Length	
Machined Contacts	
A	7 mm

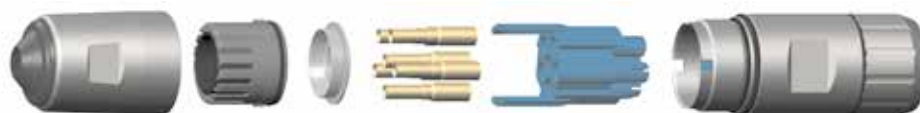

Assembly

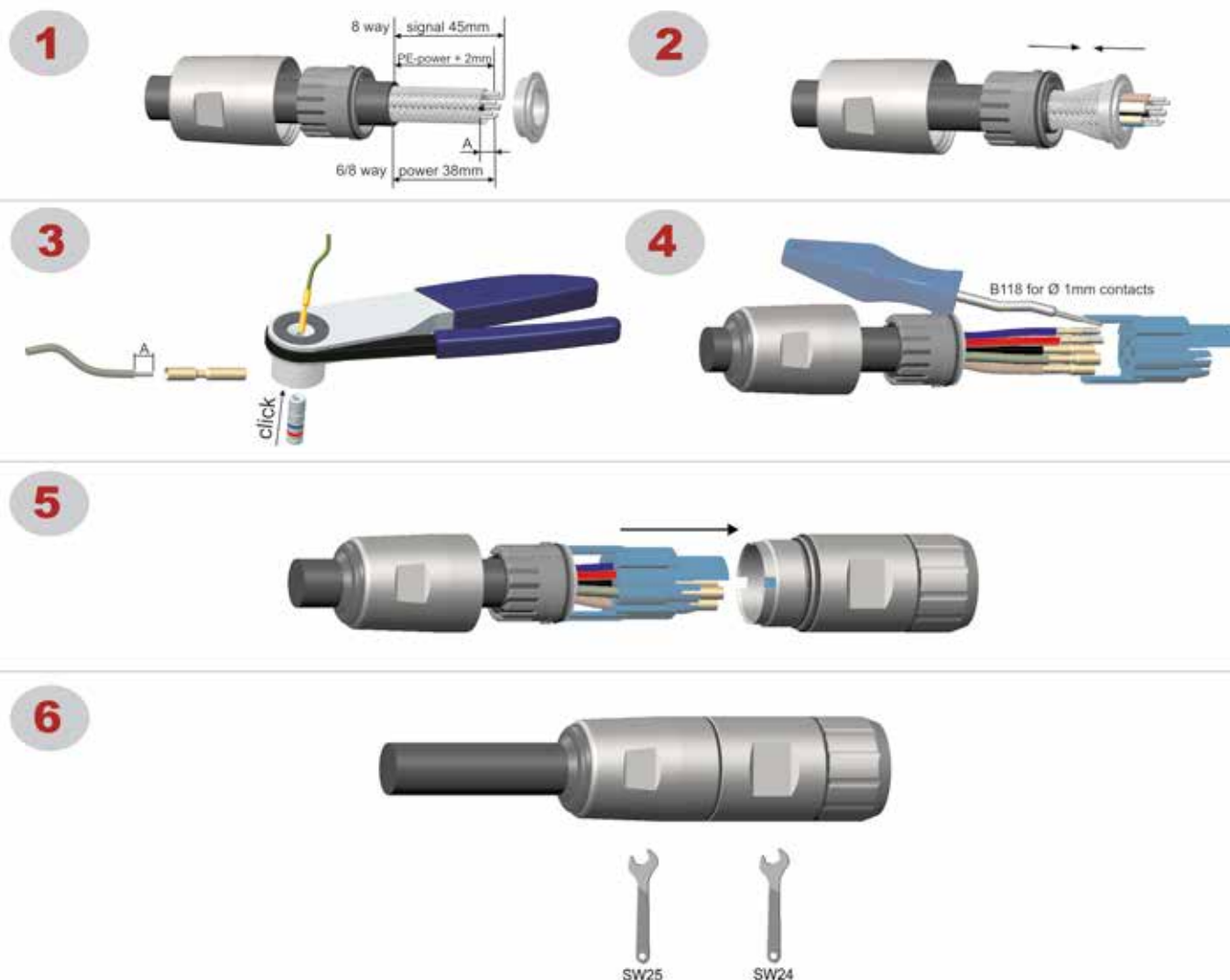

Dismantling

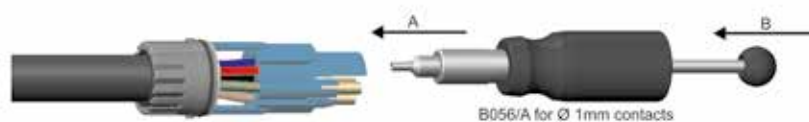

After assembly the connector has to be checked for the functions of the safety precautions (according to EN 60204-1, VDE 0113 Teil 1)

▶ ASSEMBLY INSTRUCTIONS

POWER BUSHING LDEV... LDFV... LDEV... 01 LDEV...02

Page 1 of 2

Stripping Length	
Machined Contacts	
A	7 mm

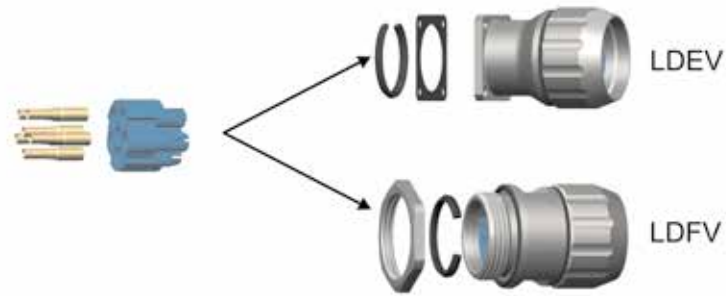

Assembly

1

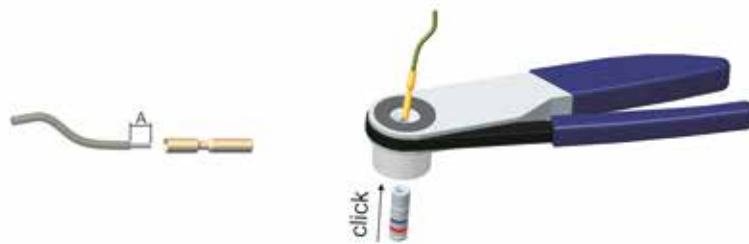

2

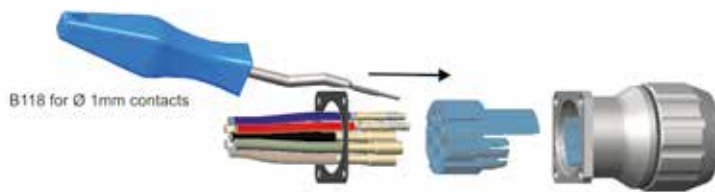

3



Dismantling



After assembly the connector has to be checked for the functions of the safety precautions (according to EN 60204-1, VDE 0113 Teil 1)

ASSEMBLY INSTRUCTIONS

POWER BUSHING LDEV... LDFV... LDEV... 01 LDEV...02

Page 2 of 2

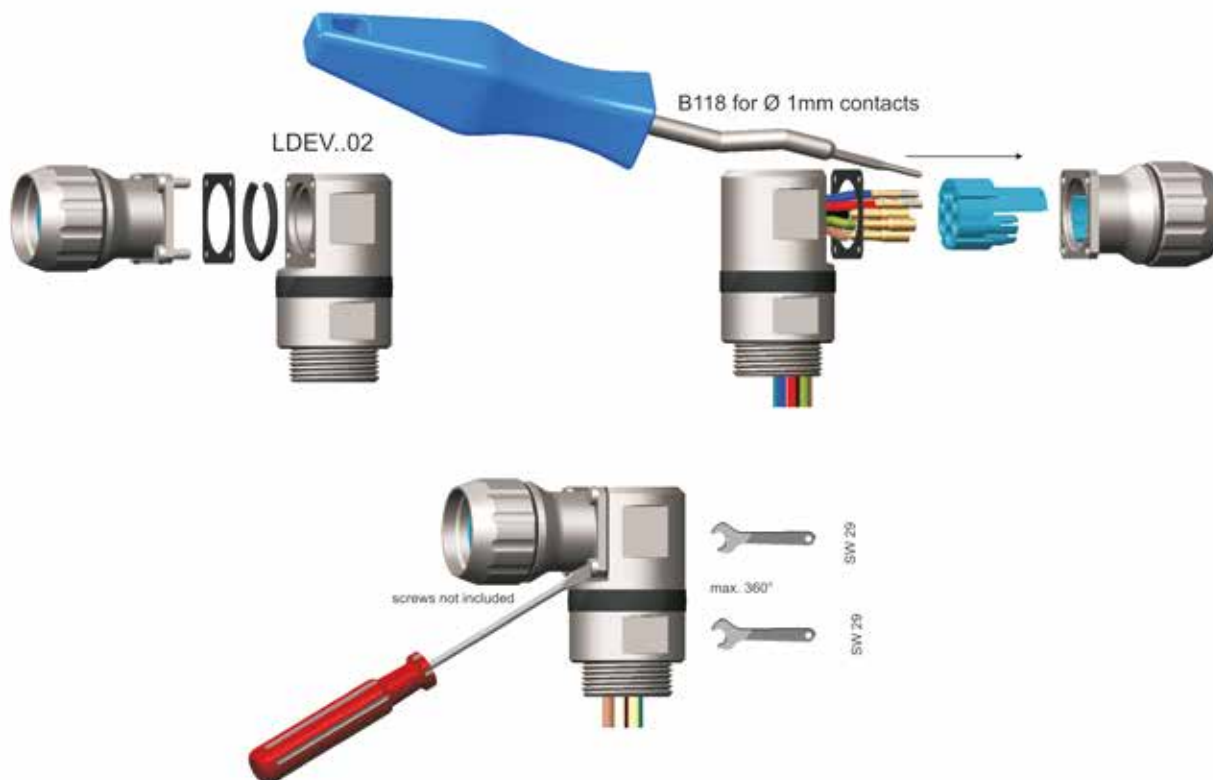
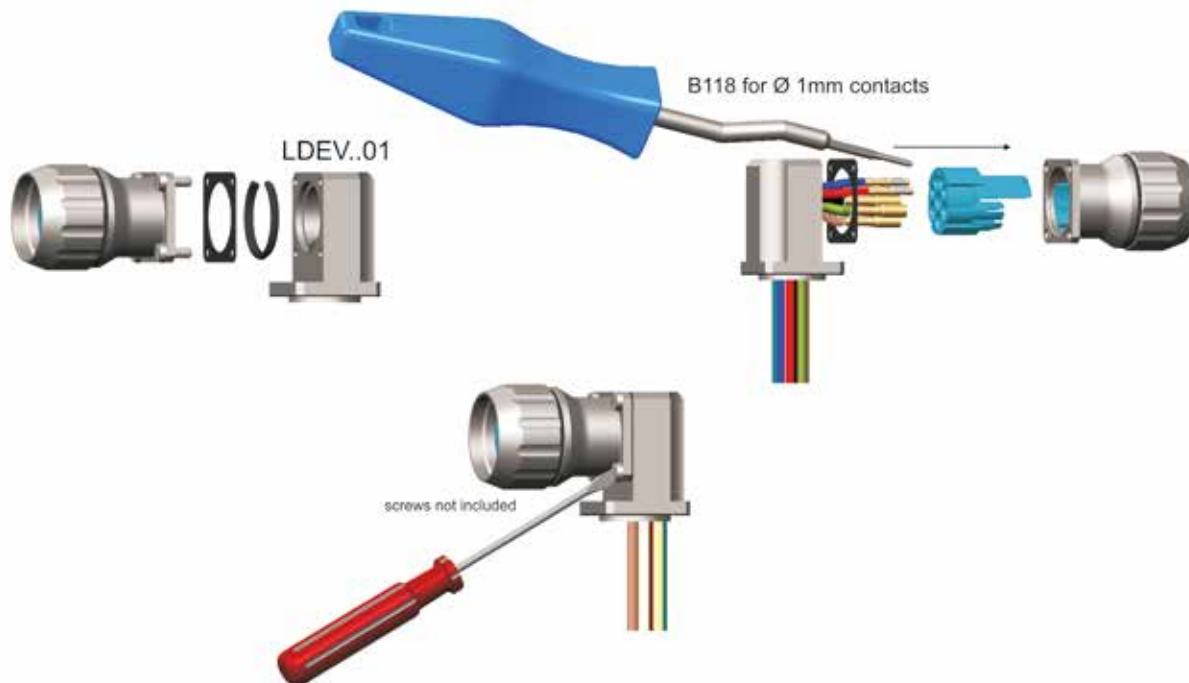

After assembly the connector has to be checked for the functions of the safety precautions (according to EN 60204-1, VDE 0113 Teil 1)

TYPE OVERVIEW

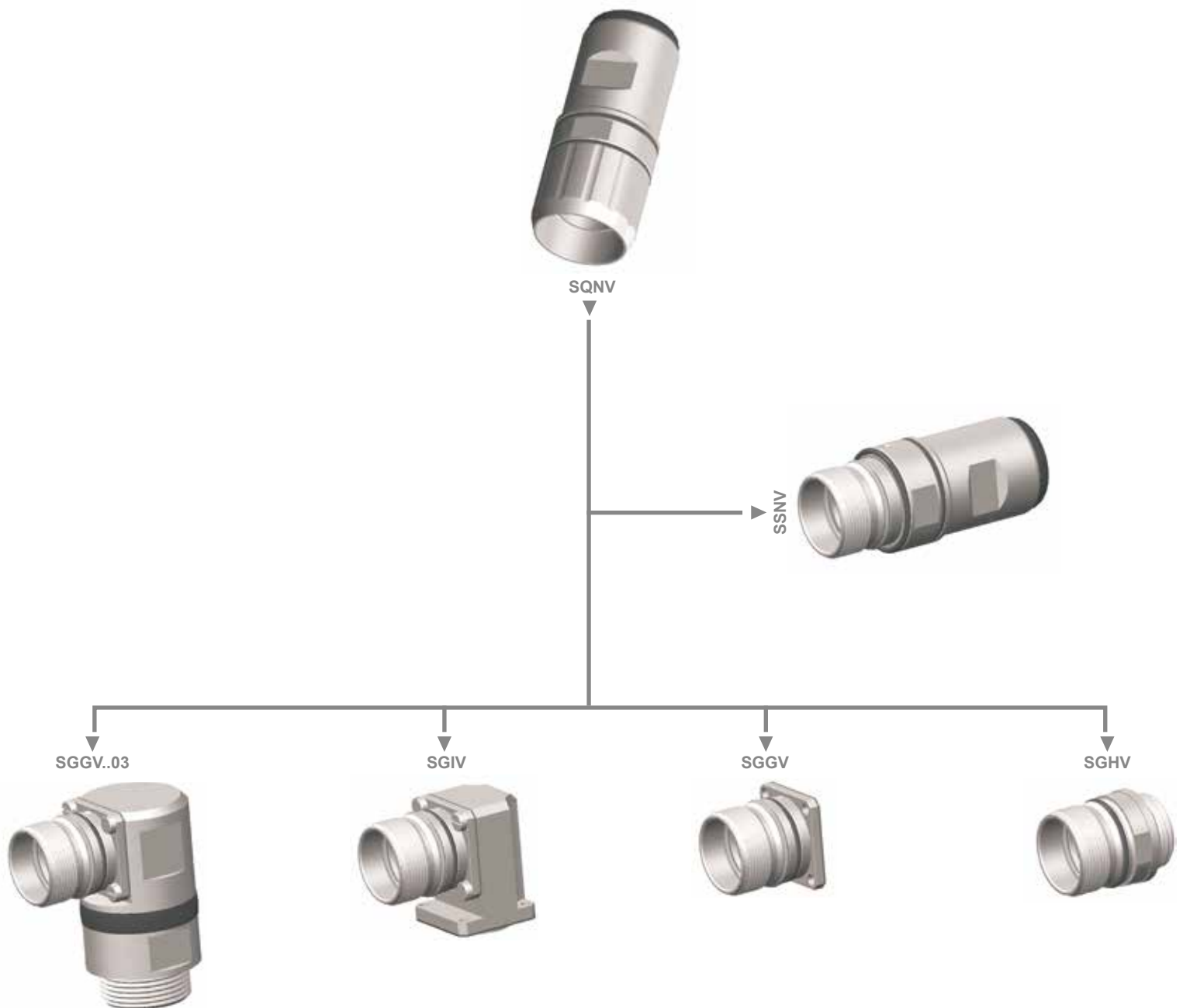

TECHNICAL CHARACTERISTICS

STAINLESS STEEL		STANDARDS
Contact diameter 6, 7 and 8poles	Ø 2mm	-
Contact diameter 9, 12, 16, 17poles	Ø 1mm	-
MATERIAL		
Shell	V2A (V4A on demand)	-
Contacts	CuZn alloy	-
Insert	PA, PBT	-
Sealing	FKM, EPDM	-
FINISHES		
Shell plating	passivated	-
Machined contacts plating	Gold over nickel	-
Stamped contacts plating	Partly gold plated	-
ELECTRICAL		
Current rating	9 A (contact Ø 1mm)	EN 61984
	8 A (contact Ø 1mm)	USR / UL1977
Voltage rating	20 A (contact Ø 2mm)	EN 61984
	20 A (contact Ø 2mm)	USR / UL1977
Withstanding voltage	50 V AC / 120 V DC 125 V	EN 61140 USR / UL1977
Contact resistance	2500 V	EN 61984
Insulation resistance	<5 mΩ (contact Ø 1mm)	EN 61984
	<3 mΩ (contact Ø 2mm)	EN 61984
Overvoltage category	10 ¹³ Ωcm (contact Ø 1mm)	EN 61984
	10 ¹⁶ Ωcm (contact Ø 2mm)	EN 61984
PHYSICAL AND ENVIRONMENTAL		
Operating temperature range	III	EN 61984
Storage conditions	-40°C ... 125°C	EN 61984
	-40°C ... 110°C	UL1977
Environmental level	-40°C ... 70°C/ min. humidity 40%	-
Contamination level	IP67 (mated)	DIN EN 60529
Installation altitude	3 (mated)	EN 61984
Fire & Smoke	up to 2000 m	EN 61984
	Recognition file No E 178462	UL 1977

Consult factory for details



HOW TO ORDER



1 CONNECTOR FAMILIES

S M23 stainless steel circular connectors, Series S

2 CONNECTOR DESIGN

Q N plug with variable shield connection and variable cable clamp
S N extension with variable shield connection and variable cable clamp

G G straight receptacle with flange
G I angled receptacle with flange
G H straight receptacle, threaded connection M 20x1.5

3 PLATING

V passivated

4 INSERTS

0 6 G 6 x Ø 2mm for extensions and receptacles
0 7 C 7 x Ø 2mm for extensions and receptacle
0 9 E 8 x Ø 1mm + 1 x Ø 2mm for extensions and receptacle
0 9 G 6 x Ø 1mm + 3 x Ø 2mm for extensions and receptacle
0 9 J 9 x Ø 1mm for extensions and receptacle
1 2 T 12 x Ø 1mm for extensions and receptacle
1 2 V 12 x Ø 1mm (Code 20°) for extensions and receptacle
1 6 A 16 x Ø 1mm for extensions and receptacle
1 7 G 17 x Ø 1mm for extensions and receptacle

0 6 H 6 x Ø 2mm for plugs
0 7 D 7 x Ø 2mm for plugs
0 9 F 8 x Ø 1mm + 1 x Ø 2mm for plugs
0 9 H 6 x Ø 1mm + 3 x Ø 2mm for plugs
0 9 K 9 x Ø 1mm for plugs
1 2 S 12 x Ø 1mm for plugs
1 2 U 12 x Ø 1mm (Code 20°) for plugs
1 6 B 16 x Ø 1mm for plugs
1 7 H 17 x Ø 1mm for plugs

5 TERMINATION STYLE

N N N N without contacts, loose machined contacts and stamped HCS contacts on reels to be ordered separately
M R R N including machined pins, 6/7 x Ø 2mm AWG 18-14
M R V N including machined pins, 6/7 x Ø 2mm AWG 24-16
M R S R including machined pins, 8/6 x Ø 1mm AWG 24-18 + 1/3 x Ø 2mm, AWG 18-14
M R S V including machined pins, 8/6 x Ø 1mm AWG 24-18 + 1/3 x Ø 2mm, AWG 24-16
M R W R including machined pins, 8/6 x Ø 1mm AWG 30-22 + 1/3 x Ø 2mm, AWG 18-14
M R W V including machined pins, 8/6 x Ø 1mm AWG 30-22 + 1/3 x Ø 2mm, AWG 24-16
M R S N including machined pins, 9/12/16/17 x Ø 1mm AWG 24-16
M R W N including machined pins, 9/12/16/17 x Ø 1mm AWG 30-22

F R R N including machined sockets, 6/7 x Ø 2mm AWG 20-16
F R M N including machined sockets, 6/7 x Ø 2mm AWG 18-14
F R O R including machined sockets, 8/6 x Ø 1mm AWG 24-18 + 1/3 x Ø 2mm, AWG 20-16
F R O M including machined sockets, 8/6 x Ø 1mm AWG 24-18 + 1/3 x Ø 2mm, AWG 18-14
F R P R including machined sockets, 8/6 x Ø 1mm AWG 20-16 + 1/3 x Ø 2mm, AWG 20-16
F R P M including machined sockets, 8/6 x Ø 1mm AWG 20-16 + 1/3 x Ø 2mm, AWG 18-14
F R B R including machined sockets, 8/6 x Ø 1mm AWG 30-22 + 1/3 x Ø 2mm, AWG 20-16
F R B M including machined sockets, 8/6 x Ø 1mm AWG 30-22 + 1/3 x Ø 2mm, AWG 18-14
F R O N including machined sockets, 9/12/16/17 x Ø 1mm AWG 24-18
F R P N including machined sockets, 9/12/16/17 x Ø 1mm AWG 20-16
F R B N including machined sockets, 9/12/16/17 x Ø 1mm AWG 30-22

6 CABLE CLAMPING

0 0 0 without cable clamp for receptacles
1 6 9 variable clamp for cable Ø 5.5mm to 12mm can be used for all shielded and non shielded cables

7 VERSION NUMBER

0 3 depending on type and special design see detailed description of connector design SGGV

RECEPTACLES

SIGNAL RECEPTACLES SERIES S WITH CRIMP CONTACTS

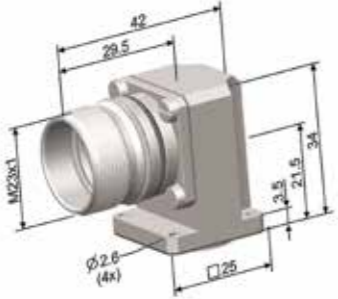
Layout Description Part number code	shell type	contact style	termination cross section
Straight receptacle, radial sealing to the device, mounting flange 	SGGV SGGV*	machined pins	0.75 - 2.5 0.24 - 1.5 0.24 - 1 / 0.75 - 2.5 0.24 - 1 / 0.24 - 1.5 0.05 - 0.34 / 0.75 - 2.5 0.05 - 0.34 / 0.24 - 1.5 0.24 - 1 0.05 - 0.34
		machined sockets	0.5 - 1.5 0.75 - 2.5 0.24 - 1 / 0.5 - 1.5 0.24 - 1 / 0.75 - 2.5 0.34 - 1.5 / 0.5 - 1.5 0.34 - 1.5 / 0.75 - 2.5 0.05 - 0.34 / 0.5 - 1.5 0.05 - 0.34 / 0.75 - 2.5 0.24 - 1 0.24 - 1.5 0.05 - 0.34
Fixed angled receptacle, radial sealing to the device, mounting flange 	SGIV SGIV*	machined pins	0.75 - 2.5 0.24 - 1.5 0.24 - 1 / 0.75 - 2.5 0.24 - 1 / 0.24 - 1.5 0.05 - 0.34 / 0.75 - 2.5 0.05 - 0.34 / 0.24 - 1.5 0.24 - 1 0.05 - 0.34
		machined sockets	0.5 - 1.5 0.75 - 2.5 0.24 - 1 / 0.5 - 1.5 0.24 - 1 / 0.75 - 2.5 0.34 - 1.5 / 0.5 - 1.5 0.34 - 1.5 / 0.75 - 2.5 0.05 - 0.34 / 0.5 - 1.5 0.05 - 0.34 / 0.75 - 2.5 0.24 - 1 0.24 - 1.5 0.05 - 0.34
		without contacts	

* UL-Version

RECEPTACLES

CONTACT ARRANGEMENTS: VIEW MATING SIDE

06G (6 x 2)		07C (7 x 2)		09E (8 x 1 / 1 x 2)		09G (6 x 1 / 3 x 2)		09J (9 x 1)		12T (12 x 1)		12V (12 x 1 Code 20°)		16A (16 x 1)		17G (17 x 1)		cable clamp		
06G 06G	MRRN MRVN	07C 07C	MRRN MRVN	09E 09E 09E 09E	MRSR MRSV MRWR MRWV	09G 09G 09G 09G	MRSR MRSV MRWR MRWV		09J 09J	MRSN MRWN	12T 12T	MRSN MRWN	12V 12V	MRSN MRWN	16A 16A	MRSN MRWN	17G 17G		MRSN MRWN	000
06G 06G	FRRN FRMN	07C 07C	FRRN FRMN	09E 09E 09E 09E 09E	FROR FROM FRPR FRPM FRBR FRBM	09G 09G 09G 09G 09G	FROR FROM FRPR FRPM FRBR FRBM		09J 09J 09J	FRON FRPN FRBN	12T 12T 12T	FRON FRPN FRBN	12V 12V 12V	FRON FRPN FRBN	16A 16A 16A	FRON FRPN FRBN	17G 17G 17G	FRON FRPN FRBN	000	
06G	NNNN	07C	NNNN	09E	NNNN	09G	NNNN	09J	NNNN	12T	NNNN	09G	NNNN	09J	NNNN	17G	NNNN			
06G 06G	MRRN MRVN	07C 07C	MRRN MRVN	09E 09E 09E 09E	MRSR MRSV MRWR MRWV	09G 09G 09G 09G	MRSR MRSV MRWR MRWV		09J 09J	MRSN MRWN	12T 12T	MRSN MRWN	12V 12V	MRSN MRWN	16A 16A	MRSN MRWN	17G 17G	MRSN MRWN	000	
06G 06G	FRRN FRMN	07C 07C	FRRN FRMN	09E 09E 09E 09E 09E	FROR FROM FRPR FRPM FRBR FRBM	09G 09G 09G 09G 09G	FROR FROM FRPR FRPM FRBR FRBM		09J 09J 09J	FRON FRPN FRBN	12T 12T 12T	FRON FRPN FRBN	12V 12V 12V	FRON FRPN FRBN	16A 16A 16A	FRON FRPN FRBN	17G 17G 17G	FRON FRPN FRBN		000
								09J	NNNN	12T	NNNN	12V	NNNN	16A	NNNN	17G	NNNN			

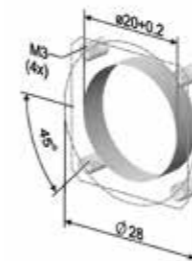

Drilling drawings

SGGV, SGIV



RECEPTACLES

SIGNAL RECEPTACLES SERIES S WITH CRIMP CONTACTS

Layout Description Part number code	shell type	contact style	termination cross section
Straight receptacle, radial sealing to the device, mounting flange 	SGGV SGGV*	machined pins	0.75 - 2.5 0.24 - 1.5 0.24 - 1 / 0.75 - 2.5 0.24 - 1 / 0.24 - 1.5 0.05 - 0.34 / 0.75 - 2.5 0.05 - 0.34 / 0.24 - 1.5 0.24 - 1 0.05 - 0.34
		machined sockets	0.5 - 1.5 0.75 - 2.5 0.24 - 1 / 0.5 - 1.5 0.24 - 1 / 0.75 - 2.5 0.34 - 1.5 / 0.5 - 1.5 0.34 - 1.5 / 0.75 - 2.5 0.05 - 0.34 / 0.5 - 1.5 0.05 - 0.34 / 0.75 - 2.5 0.24 - 1 0.24 - 1.5 0.05 - 0.34
Fixed angled receptacle, radial sealing to the device, mounting flange 	SGHV SGHV*	machined pins	0.75 - 2.5 0.24 - 1.5 0.24 - 1 / 0.75 - 2.5 0.24 - 1 / 0.24 - 1.5 0.05 - 0.34 / 0.75 - 2.5 0.05 - 0.34 / 0.24 - 1.5 0.24 - 1 0.05 - 0.34
		machined sockets	0.5 - 1.5 0.75 - 2.5 0.24 - 1 / 0.5 - 1.5 0.24 - 1 / 0.75 - 2.5 0.34 - 1.5 / 0.5 - 1.5 0.34 - 1.5 / 0.75 - 2.5 0.05 - 0.34 / 0.5 - 1.5 0.05 - 0.34 / 0.75 - 2.5 0.24 - 1 0.24 - 1.5 0.05 - 0.34
		without contacts	

* UL-Version

RECEPTACLES

CONTACT ARRANGEMENTS: VIEW MATING SIDE

06G (6 x 2)		07C (7 x 2)		09E (8 x 1 / 1 x 2)		09G (6 x 1 / 3 x 2)		09J (9 x 1)		12T (12 x 1)		12V (12 x 1 Code 20°)		16A (16 x 1)		17G (17 x 1)		cable clamp		
06G 06G	MRRN MRVN	07C 07C	MRRN MRVN	09E 09E 09E 09E	MRSR MRSV MRWR MRWV	09G 09G 09G 09G	MRSR MRSV MRWR MRWV			09J 09J	MRSN MRWN	12T 12T	MRSN MRWN	12V 12V	MRSN MRWN	16A 16A	MRSN MRWN		17G 17G	MRSN MRWN
06G 06G	FRRN FRMN	07C 07C	FRRN FRMN	09E 09E 09E 09E 09E 09E	FROR FROM FRPR FRPM FRBR FRBM	09G 09G 09G 09G 09G 09G	FROR FROM FRPR FRPM FRBR FRBM			09J 09J 09J	FRON FRPN FRBN	12T 12T 12T	FRON FRPN FRBN	12V 12V 12V	FRON FRPN FRBN	16A 16A 16A	FRON FRPN FRBN	17G 17G 17G	FRON FRPN FRBN	000
06G 06G	NNNN NNNN	07C 07C	NNNN NNNN	09E 09E 09E 09E	NNNN NNNN NNNN NNNN	09G 09G 09G 09G	NNNN NNNN NNNN NNNN			09J 09J 09J	NNNN NNNN NNNN	12T 12T 12T	NNNN NNNN NNNN	12V 12V 12V	NNNN NNNN NNNN	16A 16A 16A	NNNN NNNN NNNN	17G 17G 17G	NNNN NNNN NNNN	

Drilling drawings

SGGV.03

SGHV



EXTENSIONS

SIGNAL EXTENSION SERIES S WITH CRIMP CONTACTS

Layout Description Part number code	shell type	contact style	termination cross section
Extension with variable shield connection and variable cable clamp.	SSNV SSNV*	machined pins	0.75 - 2.5 0.24 - 1.5 0.24 - 1 / 0.75 - 2.5 0.24 - 1 / 0.24 - 1.5 0.05 - 0.34 / 0.75 - 2.5 0.05 - 0.34 / 0.24 - 1.5 0.24 - 1 0.05 - 0.34
		machined sockets	0.5 - 1.5 0.75 - 2.5 0.24 - 1 / 0.5 - 1.5 0.24 - 1 / 0.75 - 2.5 0.34 - 1.5 / 0.5 - 1.5 0.34 - 1.5 / 0.75 - 2.5 0.05 - 0.34 / 0.5 - 1.5 0.05 - 0.34 / 0.75 - 2.5 0.24 - 1 0.24 - 1.5 0.05 - 0.34
		without contacts	

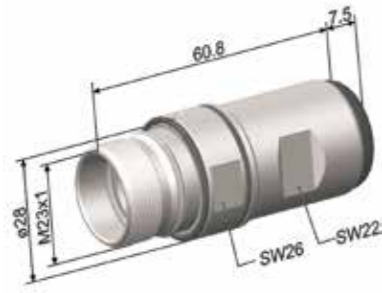

* UL-Version

EXTENSIONS

CONTACT ARRANGEMENTS: VIEW MATING SIDE

06G (6 x 2)		07C (7 x 2)		09E (8 x 1 / 1 x 2)		09G (6 x 1 / 3 x 2)		09J (9 x 1)		12T (12 x 1)		12V (12 x 1 Code 20°)		16A (16 x 1)		17G (17 x 1)		cable clamp	
06G	MRRN	07C	MRRN	09E	MRSR	09G	MRSR												169
06G	MRVN	07C	MRVN	09E	MRSV	09G	MRSV												
				09E	MRWR	09G	MRWR			09J	MRSN	12T	MRSN	12V	MRSN	16A	MRSN	17G	MRSN
				09E	MRWV	09G	MRWV			09J	MRWN	12T	MRWN	12V	MRWN	16A	MRWN	17G	MRWN
06G	FRRN	07C	FRRN	09E	FROR	09G	FROR												
06G	FRMN	07C	FRMN	09E	FROM	09G	FROM												
				09E	FRPR	09G	FRPR												
				09E	FRPM	09G	FRPM												
				09E	FRBR	09G	FRBR			09J	FRON	12T	FRON	12V	FRON	16A	FRON	17G	FRON
				09E	FRBM	09G	FRBM			09J	FRPN	12T	FRPN	12V	FRPN	16A	FRPN	17G	FRPN
										09J	FRBN	12T	FRBN	12V	FRBN	16A	FRBN	17G	FRBN
										09J	NNNN	12T	NNNN	12V	NNNN	16A	NNNN	17G	NNNN

PLUGS

SIGNAL PLUGS SERIES S WITH CRIMP CONTACTS

Layout Description Part number code	shell type	contact style	termination cross section
Plug with variable shield connection and variable cable clamp.	SQNV SQNV*	machined pins	0.75 - 2.5
			0.24 - 1.5
			0.24 - 1 / 0.75 - 2.5
		machined sockets	0.24 - 1 / 0.24 - 1.5
			0.05 - 0.34 / 0.75 - 2.5
			0.05 - 0.34 / 0.24 - 1.5
			0.24 - 1
			0.05 - 0.34
			0.5 - 1.5
			0.75 - 2.5
			0.24 - 1 / 0.5 - 1.5
			0.24 - 1 / 0.75 - 2.5
			0.34 - 1.5 / 0.5 - 1.5
0.34 - 1.5 / 0.75 - 2.5			
0.05 - 0.34 / 0.5 - 1.5			
0.05 - 0.34 / 0.75 - 2.5			
0.24 - 1			
0.24 - 1.5			
0.05 - 0.34			
		without contacts	

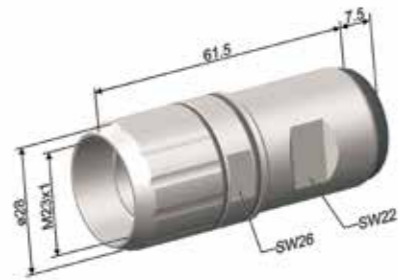







* UL-Version

PLUGS

CONTACT ARRANGEMENTS: VIEW MATING SIDE

06H (6 x 2)		07D (7 x 2)		09F (8 x 1 / 1 x 2)		09H (6 x 1 / 3 x 2)		09K (9 x 1)		12S (12 x 1)		12U (12 x 1 Code 20°)		16B (16 x 1)		17H (17 x 1)		cable clamp
06H 06H	MRRN MRVN	07D 07D	MRRN MRVN	09F 09F 09F 09F	MRSR MRSV MRWR MRWV	09H 09H 09H 09H	MRSR MRSV MRWR MRWV	09K 09K	MRSN MRWN	12S 12S	MRSN MRWN	12U 12U	MRSN MRWN	16B 16B	MRSN MRWN	17H 17H	MRSN MRWN	
06H 06H	FRRN FRMN	07D 07D	FRRN FRMN	09F 09F 09F 09F 09F 09F	FROR FROM FRPR FRPM FRBR FRBM	09H 09H 09H 09H 09H 09H	FROR FROM FRPR FRPM FRBR FRBM	09K 09K 09K	FRON FRPN FRBN	12S 12S 12S	FRON FRPN FRBN	12U 12U 12U	FRON FRPN FRBN	16B 16B 16B	FRON FRPN FRBN	17H 17H 17H	FRON FRPN FRBN	
								09K NNNN	FRON FRPN FRBN	12S NNNN	FRON FRPN FRBN	12U NNNN	FRON FRPN FRBN	16B NNNN	FRON FRPN FRBN	17H NNNN	FRON FRPN FRBN	





CONTACTS

MACHINED PINS SERIES S						
Type	R	V	S	T	W	
Contact diameter [mm]	2	2	1	1	1	
Part number and layout	021.310.1020 	021.356.1020 	021.311.1020 	021.373.1020 	021.402.1020 	
Termination cross section* [mm ²] AWG	0.75 - 2.5 (18 - 14)	0.34 - 1.5 (24 - 16)	0.24 - 1.0 (24 - 18)	0.24 - 1.0 (24 - 18)	0.05 - 0.34 (30 - 22)	
Max. nominal current [A] (20°C) at max. cross section	20	20	9	9	9	
Strip length (A) [mm]	~ 5.5	~ 5.5	(B = $\varnothing 2.1$) ~ 4 (B = >math>\varnothing 2.1</math>) ~ 6	(B = $\varnothing 2.1$) ~ 4 (B = >math>\varnothing 2.1</math>) ~ 6	~ 5	
Contact resistance [mΩ]	<3	<3	<5	<5	<5	
Max. conductor diameter [mm]	2.2	1.8	1.2	1.2	0.8	
Max. insulation diameter [mm] for insulation crimp	-	-	2.1	2.1	-	

*Mentioned crimp ranges are recommendations and only valid with flexible wires H05(07)V-K [mm²] acc. to DIN VDE 0281/0282 pp and with non compressed standard cables and wires acc. to DIN VDE 0295. It is possible that due to another structure of wires further cross sections and currents can be processed.

TOOLING						
Part Number						
Hand crimping tool	B151	B151	B150	B150	B150	
Positioner	B201	B201	B055/A	B055/A	B055/A	
Insertion tool	-	-	-	-	-	
Extraction tool	-	-	-	-	-	

CONTACTS

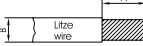



MACHINED SOCKETS SERIES S						
Type	R	M	O	P	B	
Contact diameter [mm]	2	2	1	1	1	
Part number and layout	020.315.1020 	020.263.1020 	020.256.1020 	020.328.1020 	020.353.1020 	
Termination cross section* [mm ²] AWG	0.5 - 1.5 (20 - 16)	0.75 - 2.5 (18 - 14)	0.24 - 1.0 (24 - 18)	0.5 - 1.5 (20 - 16)	0.05 - 0.34 (30 - 22)	
Max. nominal current [A] (20°C) at max. cross section	20	20	9	9	9	
Strip length (A) [mm]	~ 5.5	~ 5.5	(B = $\varnothing 2.1$) ~ 4 (B = >math>\varnothing 2.1</math>) ~ 6	~ 5	~ 5	
Contact resistance [mΩ]	<3	<3	<5	<5	<5	
Max. conductor diameter [mm]	1.7	2.2	1.2	-	-	
Max. insulation diameter [mm] for insulation crimp	-	-	2.1	-	-	

*Mentioned crimp ranges are recommendations and only valid with flexible wires H05(07)V-K [mm²] acc. to DIN VDE 0281/0282 pp and with non compressed standard cables and wires acc. to DIN VDE 0295. It is possible that due to another structure of wires further cross sections and currents can be processed.

TOOLING						
Part Number						
Hand crimping tool	B151	B151	B150	B151	B150	
Positioner	B201	B201	B055/A	B257	B055/A	
Insertion tool	-	-	-	-	-	
Extraction tool	-	-	-	-	-	

CONTACTS

STAMPED HCST™ PINS SERIES S

Type	A	B	C	D		
Contact diameter [mm]	1	1	1	1		
Part number and layout	021.001005.1025 	021.001006.1025 	021.001007.1025 	021.001008.1025 		
Termination cross section* [mm²] AWG	0.03 - 0.08 (32 - 28)	0.08 - 0.2 (28 - 24)	0.2 - 0.5 (24 - 20)	0.75 - 1.0 (18)		
Max. nominal current [A] (20°C) at max. cross section	4	6	8	8		
Strip length (A) [mm]	~ 3	~ 3	~ 3	~ 3		
Contact resistance [mΩ]	<5	<5	<5	<5		
9000 pcs. big reel part number	021.001005.1025	021.001006.1025	021.001007.1025	021.001008.1025		
3000 pcs. big reel part number	021.001005.1025.A2	021.001006.1025.A2	021.001007.1025.A2	021.001008.1025.A2		





*Mentioned crimp ranges are recommendations and only valid with flexible wires H05(07)V-K [mm²] acc. to DIN VDE 0281/0282 pp and with non compressed standard cables and wires acc. to DIN VDE 0295. It is possible that due to another structure of wires further cross sections and currents can be processed.

TOOLING

Part Number						
Hand crimping tool for small reels	B287/32-28	B287/28-24	B287/24-20	B287/0.75-1		
Hand crimping tool for discrete contacts	B326	B326	B326	B326		
Positioner for discrete contacts	B326/1	B326/1	B326/2	B326/2		
Applicator for crimping machine	B288/32-28 B286/32-28	B288/28-24 B286/28-24	B288/24-20 B286/24-20	B288/0.75-1 B286/0.75-1	Schäfer ** Kirsten PP3	

**acc. to AMP standard

CONTACTS

STAMPED HCS™ SOCKETS SERIES S					
Type	A	B	C	D	
Contact diameter [mm]	1	1	1	1	
Part number and layout	020.000376.2000 	020.000377.2000 	020.000378.2000 	020.000379.2000 	
Termination cross section* [mm ²] AWG	0.03 - 0.08 (32 - 28)	0.08 - 0.2 (28 - 24)	0.2 - 0.5 (24 - 20)	0.75 - 1.0 (18)	
Max. nominal current [A] (20°C) at max. cross section	4	6	8	8	
Strip length (A) [mm]	~ 3	~ 3	~ 3	~ 3	
Contact resistance [mΩ]	<5	<5	<5	<5	
9000 pcs. big reel part number	020.000376.2000	020.000377.2000	020.000378.2000	020.000379.2000	
3000 pcs. big reel part number	020.000376.2000.A2	020.000377.2000.A2	020.000378.2000.A2	020.000379.2000.A2	

*Mentioned crimp ranges are recommendations and only valid with flexible wires H05(07)V-K [mm²] acc. to DIN VDE 0281/0282 pp and with non compressed standard cables and wires acc. to DIN VDE 0295. It is possible that due to another structure of wires further cross sections and currents can be processed.

TOOLING					
Part Number					
Hand crimping tool for small reels	B287/32-28	B287/28-24	B287/24-20	B287/0.75-1	
Hand crimping tool for discrete contacts	B326	B326	B326	B326	
Positioner for discrete contacts	B326/1	B326/1	B326/2	B326/2	
Applicator for crimping machine	B288/32-28 B286/32-28	B288/28-24 B286/28-24	B288/24-20 B286/24-20	B288/0.75-1 B286/0.75-1	Schäfer ** Kirsten PP3

**acc. to AMP standard

► ASSEMBLY INSTRUCTIONS

SIGNAL EXTENSION SSVN...

Page 1 of 1

Stripping Length		
	Machined Contacts	Stamped Contacts
A	see catalogue page 32 - 33	~3 mm



Assembly



Dismantling

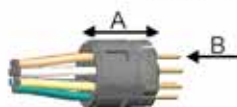

After assembly the connector has to be checked for the functions of the safety precautions (according to EN 60204-1, VDE 0113 Teil 1)

ASSEMBLY INSTRUCTIONS

SIGNAL PLUG SQNV...

Page 1 of 1

	Stripping Length	
	Machined Contacts	Stamped Contacts
A	see catalogue page 32 - 33	~3 mm



Assembly

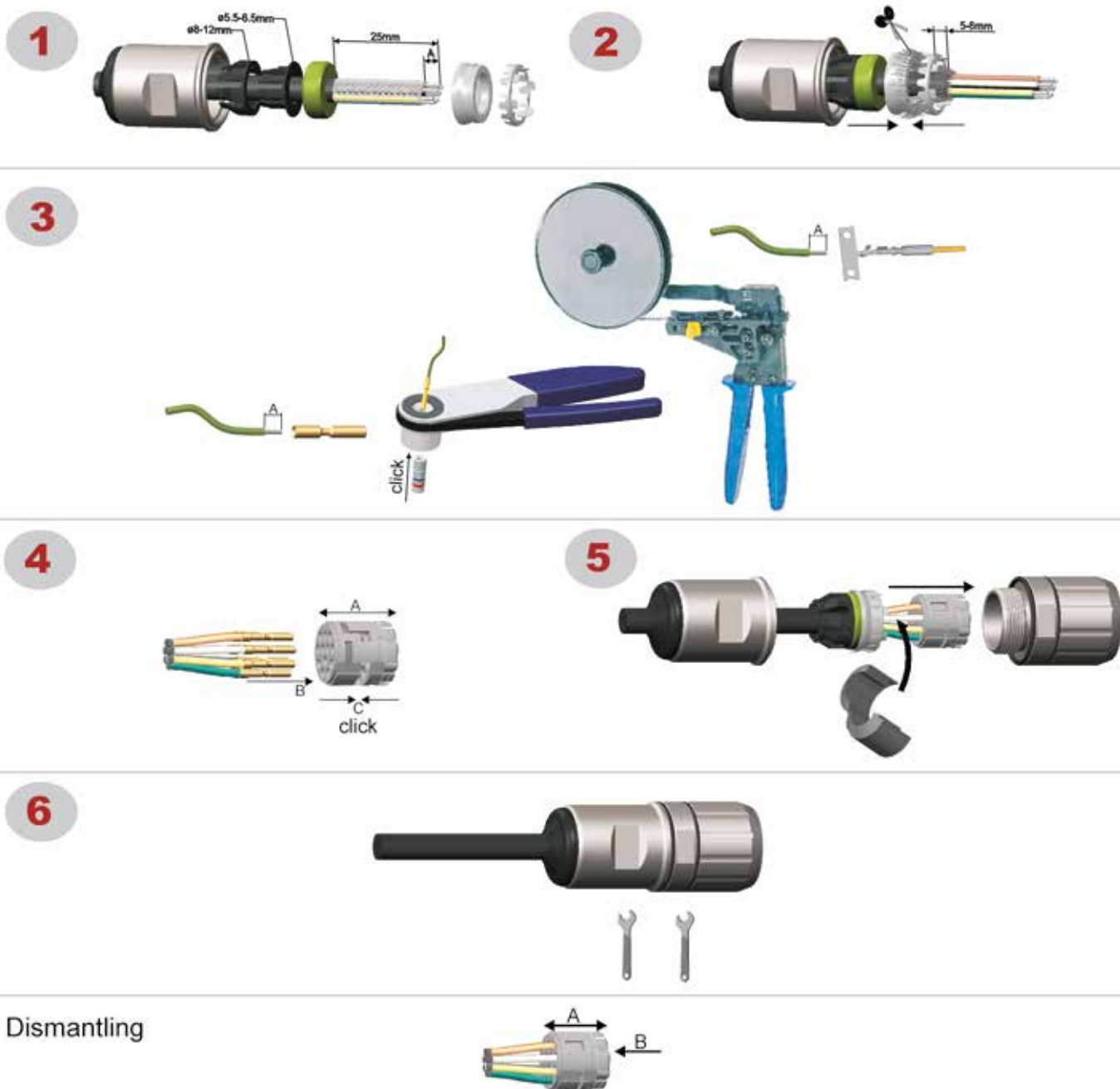

Dismantling



After assembly the connector has to be checked for the functions of the safety precautions (according to EN 60204-1, VDE 0113 Teil 1)

▶ ASSEMBLY INSTRUCTIONS

SIGNAL RECEPTACLE SGGV...SGHV...SGIV...SGGV.03

Page 1 of 2

	Stripping Length	
	Machined Contacts	Stamped Contacts
A	see catalogue page 32 - 33	~3 mm



Assembly

1



2

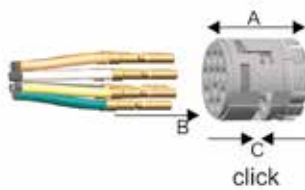

3



Dismantling



After assembly the connector has to be checked for the functions of the safety precautions (according to EN 60204-1, VDE 0113 Teil 1)

ASSEMBLY INSTRUCTIONS

SIGNAL RECEPTACLE SGGV...SGHV...SGIV...SGGV..03



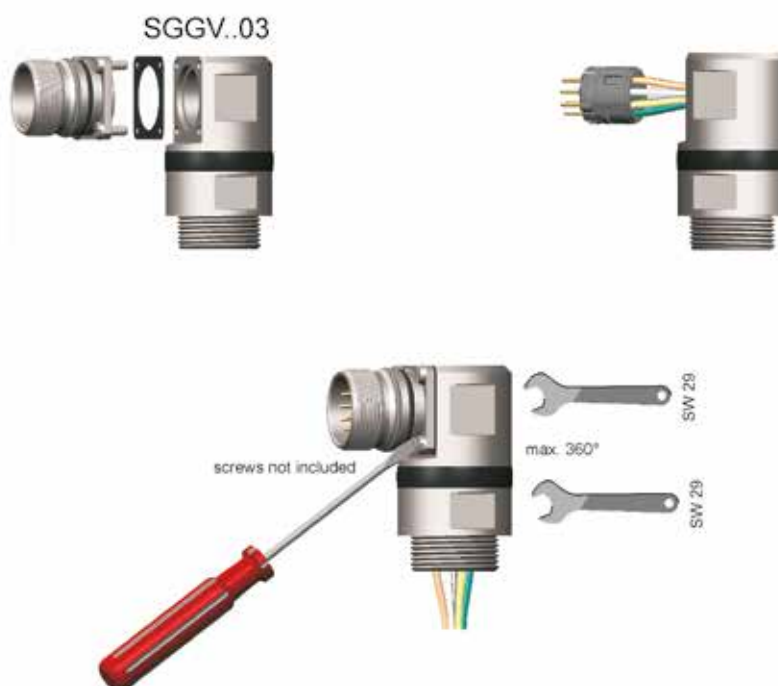
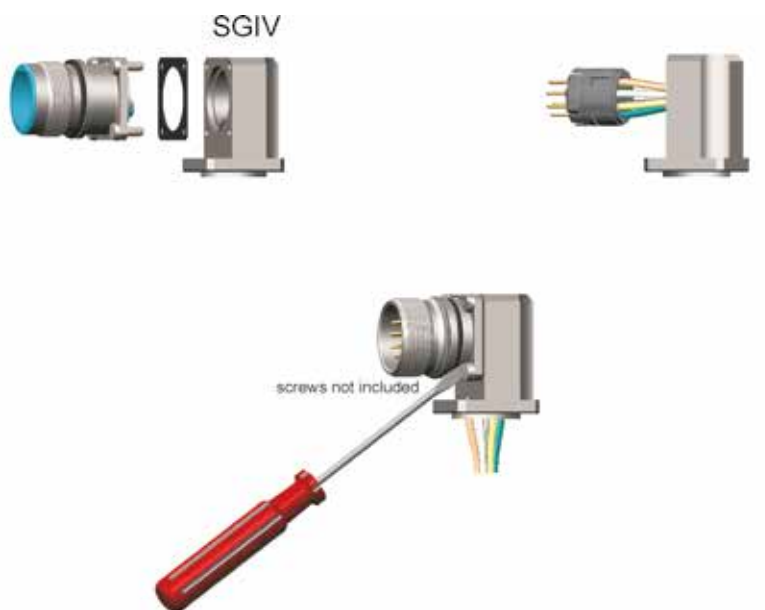

Page 2 of 2







After assembly the connector has to be checked for the functions of the safety precautions (according to EN 60204-1, VDE 0113 Teil 1)

► TOOLS

CRIMPING TOOLS FOR MACHINED CONTACTS







Hand crimping tool	Positioner	Part number
 <p>Part number B150</p>		B055/A B201 B245 B257 B297 B305 B306
Hand crimping tool	Master Gauge	Part number
 <p>Part number B151</p>		B190 B230

INSERTION AND EXTRACTION TOOLS

Insertion tool	Extraction tool	Part number
 <p>Part number B117</p>		B132
 <p>Part number B118</p>		B037/10a
		B038/10

TOOLS

CRIMPING TOOLS FOR STAMPED HCS™ CONTACTS

Hand crimping tools with feeder line for HCS™ Ø 1mm	Termination Cross Section	Part number
 <p>Part number B287/..</p>	0.032 - 0.08mm ² (AWG 32-28) 0.08 - 0.20mm ² (AWG 28-24) 0.20 - 0.52mm ² (AWG 24-20) 0.75 - 1.00mm ²	B287/32-28 B287/28-24 B287/24-20 B287/0.75-1.00
Hand crimping tools for discrete HCS™ Ø 1mm contacts	Positioner	Part number
 <p>Part number B326</p>		B326/1 B326/2 B326/3
Crimping tool set incl. 3 positioners (A, B, C)	Positioner separately	Part number
 <p>27</p>	<p>Positioner A (AWG 32-24)</p> <p>Positioner B 0.50 - 1.00mm² (AWG 24-20)</p> <p>Positioner C 1.50 - 4.00mm²</p>	B326/1 B326/2 B326/3
Applicators for crimping machines with feeder line	HCS™ Ø 1mm termination cross section	Part number
 <p>AMP / Schäfer ESP1000</p>	0.032 - 0.08mm ² (AWG 32-28) 0.08 - 0.20mm ² (AWG 28-24) 0.20 - 0.52mm ² (AWG 24-20) 0.75 - 1.00mm ²	B288/32 - 28 B288/28 - 24 B288/24 - 20 B288/0.75 - 1.00
Applicators for crimping machines with feeder line	HCS™ Ø 1mm termination cross section	Part number
 <p>Kirsten PP3</p>	0.032 - 0.08mm ² (AWG 32-28) 0.08 - 0.20mm ² (AWG 28-24) 0.20 - 0.52mm ² (AWG 24-20) 0.75 - 1.00mm ²	B286/32 - 28 B286/28 - 24 B286/24 - 20 B286/0.75 - 1.00

▶ **CABLE CLAMPS**

CABLE CLAMPS

<p>Cable clamp No. 169 for SSNV/SQNV</p> 	<p>Clamp range</p> <p>with reducing sleeve from 5.5 - 8.5mm without reducing sleeve from 8-12mm can be used for shielded and non shielded cables</p>
<p>Cable clamp No. 170 for LSNV</p> 	<p>Clamp range</p> <p>with reducing sleeve from 7.7 - 12mm without reducing sleeve from 11-14.5mm can be used for shielded and non shielded cables</p>
<p>Cable clamps No. 305/306/307 for LQNV</p> 	<p>Clamp range</p> <p>.305 cable diameter 5 - 9 mm .306 cable diameter 9 -15 mm .307 cable diameter 16 mm</p> <p>can be used for shielded and non shielded cables</p>

▶ ACCESSOIRES

Thread Protection Caps	Part number
	031.287.1000 (short) 031.405.1000 (long)

Dust Shield Caps	Part number	Description
	C/BEL/1	dust shield cap for extension and receptacle
	C/BEL/2	identical to C/BEL/1 with chain 75mm
	C/BEL/7	identical to C/BEL/1 with chain 120mm
	C/BEL/5	dust shield cap for power plug and panel feed through with chain 120mm
	C/BEL/6	dust shield cap for signal plug with chain 120mm

CuZn alloy dust shield caps, nickel plated. Stainless steel quality on demand

Disclaimer 2015

All of the information included in this catalogue is believed to be accurate at the time of printing. It is recommended, however, that users should independently evaluate the suitability of each product for their intended application and be sure that each product is properly installed, used and maintained to achieve desired results.

Smiths Connectors makes no warranties as to the accuracy or completeness of the information, and disclaims any liability regarding its use.

Smiths Connectors reserves the right to modify design and specifications, in order to improve quality, keep pace with technological development or meet specific production requirements.

No reproduction or use without express permission of editorial and pictorial content, in any manner.

SMITHS CONNECTORS

PRODUCT LINES

PCB

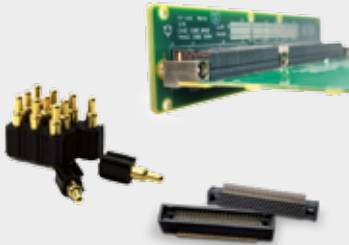

- ▶ Low, medium and high density board-to-board, cable to board and stacking
- ▶ Rugged standard
- ▶ Low profile
- ▶ Signal, power, coaxial & high speed configurations
- ▶ Self configurable board-to-board
- ▶ Spring probe connectors
- ▶ Mixed signal, power and coaxial contact connectors
- ▶ Different termination styles: solder cup, crimp, SMT and SMT flex, press fit, solder dip.

POWER



- ▶ Circular
- ▶ Configurable rectangular
- ▶ Ruggedized
- ▶ Single and Multi-Way Connectors
- ▶ Power contact up to 1,200 Amps
- ▶ Excellent performance in harsh environment conditions
- ▶ Cable assembling

EMI/EMP FILTER



- ▶ EMI/RFI filtering and transient protection
- ▶ RoHS compliant solderless filter connectors available
- ▶ Circular, ARINC, D-Subminiature Micro-D
- ▶ Filtered adapters for "bolt on" EMI /EMP solutions
- ▶ Filter hybrid capability

MODULAR/RECTANGULAR

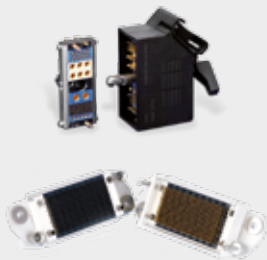

- ▶ Configurable with modules for signal, power, coax, fiber optics and/or pneumatics
- ▶ Easy configuration in a single frame
- ▶ For rack & panel, and cable applications
- ▶ Guided hardware for blind
- ▶ D-sub connectors
- ▶ Micro-D style
- ▶ Signal connectors for hand held and docking stations

CIRCULAR



- ▶ Metal and Plastic
- ▶ Industrial M12, M23, M40, M58
- ▶ Crimp and solder terminations
- ▶ Various types of cable clamps
- ▶ Push Pull/ latch mechanism
- ▶ Color coding

HEAVY DUTY



- ▶ Ultra reliable hyperboloid contact
- ▶ Modular solution: signal, power, data contacts, and fiber optics
- ▶ High resistance in harsh environment
- ▶ EMC shielding
- ▶ Easy cable mounting
- ▶ High pressure up to 35K PSI, 250° C
- ▶ High temperature up to 440° C

SPRING PROBES

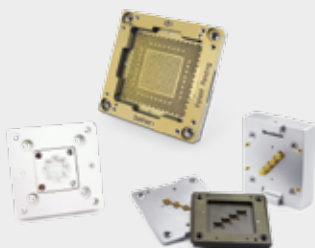

- ▶ Z-axis compliant
- ▶ Blind mate engagement
- ▶ Long cycle life
- ▶ High density
- ▶ Extreme miniaturization
- ▶ Printed circuit board test
- ▶ Bare board test
- ▶ Coaxial contacts

MIL/AERO STANDARD



- ▶ Standard military interface
- ▶ ARINC interface
- ▶ ARINC 801
- ▶ Custom inserts

HIGH SPEED COPPER/FIBER

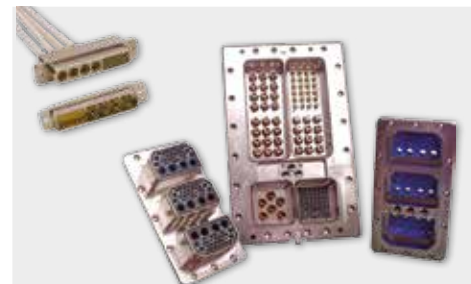

- ▶ Quadrx and Twinax Connectors
- ▶ Rugged D-Sub Connectors
- ▶ ARINC and MIL-STD Contacts
- ▶ Micro Twinax/Quadrx
- ▶ Butt-Joint and Expanded Beam Contacts
- ▶ ARINC 801 Termini
- ▶ Floating Fiber Termini



SMITHS CONNECTORS

GLOBAL SUPPORT

AMERICAS

info.us@smithsconnectors.com

Costa Mesa, CA
1.714.371.1100

Hudson, MA
1.978.568.0451

Kansas City, KS
1.913.342.5544

EUROPE

France

33.2.32969176
info.fr@smithsconnectors.com

Germany

49.991.250.120
info.de@smithsconnectors.com

Italy

39.010.60361
info.it@smithsconnectors.com

United Kingdom

44.208.236.2400
info.uk@smithsconnectors.com

ASIA

asiainfo@smithsconnectors.com

Shanghai, China
86.21.3318.4650

Suzhou, China
86.512.6273.1188

Singapore
65.6846.1655

visit us at | smithsconnectors.com |     